



IB Router 2



High-Performance InfiniBand Connectivity

FEATURES AND BENEFITS

InfiniBand to Ethernet Connectivity

- **InfiniBand Connectivity:** provides unsurpassed interactive performance and unlimited capacity for InfiniBand interconnected HPC clusters
- **Optimized Solution:** Panasas engineered, validated and supported solution provides the best value and reliability with end-to-end support
- **High Availability Configuration:**

Automated Data Path Failover

Multiple Panasas IB Routers are designed to be configured with an optional 10 GbE Ethernet switch providing alternate data path failover for seamless I/O operation

Optimized Performance:

Data Path Load Balancing

The optional 10 GbE switch configuration enables automated data path load balancing for optimal performance efficiency

Reliable and Fast Deployment:

Solution Ready

Software and hardware is preconfigured and tested, enabling fast and reliable deployment

Scientific and technical computing applications require highly robust and scalable network connectivity to support the massive throughput demands of high speed compute clusters. The Panasas IB Router 2 provides seamless connectivity from InfiniBand fabrics to Panasas ActiveStor storage solutions, delivering increased levels of performance, scalability and manageability.

Panasas IB Router

Scalable InfiniBand Connectivity for Panasas High Performance Storage

The Panasas IB Router 2 is a cost effective network connectivity option for integrating Panasas ActiveStor storage solutions with high speed, low latency InfiniBand-based compute clusters. Suitable for new and existing Panasas storage installations, the Panasas IB router provides up to four 40 Gb/s ports of flexible QDR InfiniBand bandwidth that can be used as an alternative solution when standard Ethernet connectivity is bandwidth constrained or when lower network latency is required to meet application performance demands. The Panasas IB Router is preconfigured and tested to ensure fast and reliable deployment, and it is available with Panasas' standard and extended support options for end-to-end storage solution integrity.

High Availability, Balanced Performance and Interoperability

Multiple Panasas IB Routers can be combined with an optional 10 Gb Ethernet switch providing automated and seamless data path failover for continuous network access. The multiple IB Routers and switch solution also provides data path load balancing, further reducing I/O latency for optimal performance. The Panasas IB Router is compatible with all SDR, DDR and QDR InfiniBand switches from vendors such as Cisco, Mellanox (including Voltaire), and QLogic, ensuring the highest levels of system interoperability.

Panasas Delivers

The Panasas family of scale-out NAS solutions enables enterprise customers to rapidly solve complex computing problems, speed innovation and bring new products to market faster. Panasas offers comprehensive, scalable storage solutions that deliver the highest bandwidth and I/O throughput; scalable performance and capacity; and simple unified management. Panasas integrated hardware and software solutions have been deployed in hundreds of installations around the globe, helping organizations accelerate time to results and maximizing ROI from data intensive and high performance computing environments.

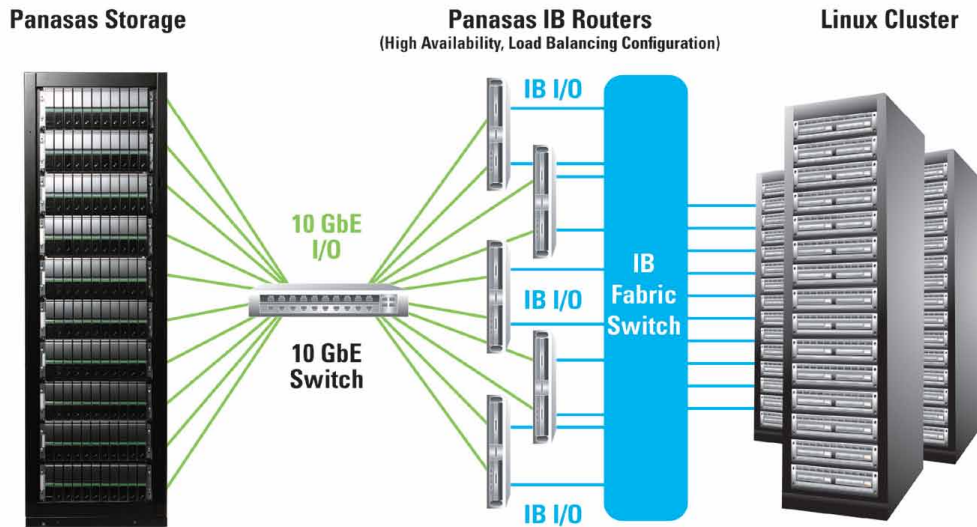

IB Router 2 Product Specifications

SYSTEM

- Chassis
 - ✦ 2U rackmount
- Router Modules per 2U Chassis
 - ✦ Up to 4 independent router modules
 - ✦ Flash boot (no moving parts)

INPUT/OUTPUT

- InfiniBand I/O Connectivity
 - ✦ One 40Gb QDR InfiniBand QSFP port per IB Router module, (4 independent InfiniBand ports per 2U chassis)
- Ethernet I/O Connectivity
 - ✦ Two 10Gb Ethernet SFP+ ports per IB Router module, (eight 10Gb Ethernet ports per 2U chassis)
 - ✦ Choice of Direct Attach or Optical cables
- Management Connectivity
 - ✦ Dedicated 10/100 Ethernet IPMI 2.0 management port

SOFTWARE

- InfiniBand Drivers
 - ✦ OFED 1.4.2

DIMENSIONS

- Height 3.5" (89mm)
- Width 17.2" (437mm)
- Depth 28.5" (724mm)
- Gross Weight 85 lbs (38.6kg)

POWER SUPPLY

- Redundant AC-DC Power Supply w/ PFC
- High Efficiency: 80Plus Gold Certified
- AC Input
 - ✦ 1200W: 100-140V, 50-60Hz, 10.5-14.7A
 - ✦ 1400W: 180-240V, 50-60Hz, 7.2-9.5A

FRONT PANEL PER NODE

- Buttons
 - ✦ Power On/Off button
- LEDs
 - ✦ Power LED
 - ✦ Network activity LED
 - ✦ System overheat/fan fail/power fail LED

ENVIRONMENTAL SPECIFICATIONS

- RoHS compliant
- Operating Temperature 10°C to 35°C (50°F to 95°F), derating applies at altitude
- Non-operating Temperature -40°C to 70°C (-40°F to 158°F)
- Operating Relative Humidity 8% to 90% (non-condensing)
- Non-operating Relative Humidity 5% to 95% (non-condensing)

SERVICE AND SUPPORT

- Standard Support
 - ✦ 90 days software, 1 year hardware
- Extended Support Options
 - ✦ Panamas Silver, Gold and Platinum Service programs

About Panamas

Panamas, Inc., the leader in high performance parallel storage for business-critical applications, enables customers to rapidly solve complex computing problems, speed innovation and accelerate new product introduction. All Panamas storage products leverage the patented Panamas® PanFS™ parallel file system to deliver superior performance, data protection, scalability, and manageability. Panamas systems are optimized for demanding storage applications in the energy, government, finance, manufacturing, bioscience, and higher education industries.

